

Wiring Schematic

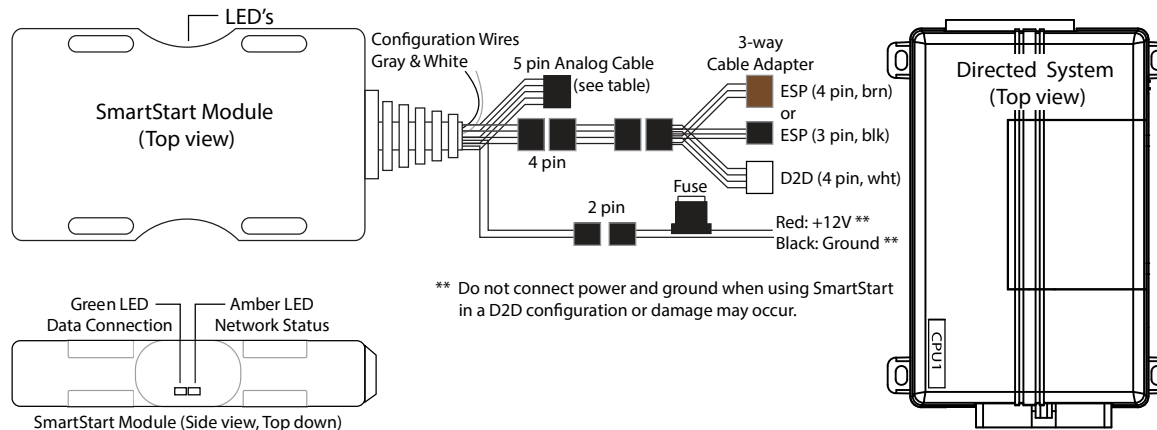

** Do not connect power and ground when using SmartStart in a D2D configuration or damage may occur.

NOTE: The appearance and connector/port arrangement on the analog or digital system being installed system may differ from the example shown.



INSTALLATION CAUTIONS

The white plug on the 3-way cable adapter is **ONLY** for use with digital platforms such as DBALL2, DBALL2PRO, 4X10 and 5X10.

For some older analog systems with combined 4-pin ESP/D2D ports, you **CANNOT** use an interface module in D2D mode when using a SmartStart module. You must use W2W on the bypass module.

DO NOT connect the black 3-pin ESP connector to white Door Lock port on Directed systems.

There should **NEVER** be more than one data plug connected from the 3-way cable adapter.

5-pin Analog Cable*		
Pin #	Wire Color	Connection/Description
1	White/Blue	(-) RS (Remote Start)/AUX output
2	Brown	(-) Factory horn/Alert input
3	Green	(-) Lock Output
4	Blue	(-) Unlock Output
5	Red/White	(-) Trunk/AUX output

* **NOTE:** The analog output wires are only active if the device has been configured for Analog Wire mode in the installation portal.

Installation Procedure

This product is compatible with most Directed digital systems, analog systems with ESP2/D2D data ports, and many Autostart and AstroStart systems with pager ports and D2D ports.

Please read the following before proceeding.

- Customer Information required:
 - Record the customer information requested in step 4a of this procedure. The module Air ID # is provided on a sticker which should be affixed to the space provided in the user's guide.

This information is required for final verification/activation of the VSM300/350 or DSM300/350.

- Installation Points:
 - Install and test the security/remote start or digital system first using the associated guides and wiring diagram. When adding SmartStart to an existing system, verify it is fully functional before installing the SmartStart module.
 - Mount the SmartStart module as high as possible in the vehicle with the engraved side facing upward (for all devices). Mount with minimal obstructions that can affect communications and within reach of the main Directed system using the provided cables (do not extend).

The module's signal strength (RSSI) can be viewed in the activation portal after a successful transmission test.

-50 to -90 dB = good signal strength
 -91 to -100 dB = borderline/inconsistent signal strength
 > -100 dB = weak, insufficient signal strength

3. Install the VSM300/350 or DSM300/350 using the information in the wiring diagram and the following steps.
 - a. **Configuration Wires:** Connect the loose gray or white configuration wire(s) to match the desired application (see the following chart).

Configuration Wires Chart

MODE	GRAY WIRE	WHITE WIRE
ESP2*	No Connection	No Connection
D2D, RSR/RXT**	GND	No Connection
Autostart/Astro-Start	No Connection	GND

- * Directed systems for Viper, Python, Clifford, Avital and Automate.
- ** Directed digital systems.

- b. Connect the serial data cable and adapter to the correct port of the main module. Use the following chart to determine which connection is required for the application being used.

3-way Cable Adapter Chart

Cable Adapter Connector	Cable Adapter Application
ESP 4-pin Brown	Use in systems that have one port for D2D and ESP2
ESP 3-pin Black	Use in systems that have a separate port for D2D and ESP2
D2D 4-pin White	Use in digital systems such as DBALL2, DBALL2Pro, 4X10, 5X10

- c. Complete the main power connections, if required (see ** note in wiring diagram on previous page).
- d. When power is connected, the module begins an initialization procedure that may take several minutes. During this procedure, progress is reported via the flashing Amber/Green LEDs on the side of

the SmartStart module. When both LEDs turn on solid, the initialization procedure is completed (See *LED Status Chart* for a description of the various LED states).

4. Verify and Activate the SmartStart module: The following steps need to be performed for the Verification/Activation of the Directed SmartStart module.

- a. Collect Customer Information:

Customer's E-mail Address:

Customer's mobile phone #

Record Module ID # here:

New Account: Existing Account:

- b. Log on to: www.directechs.com, and click on the SmartStart Activation link.
- c. Follow the on-screen directions to activate and test a SmartStart device. If this is the customer's first SmartStart system, you will be prompted to enter their information as collected in step 4a.
- d. Set configuration for commands to match the installed application.
- e. Test the SmartStart system from the website using the supplied function links.
- f. The customer is sent log-in information via e-mail. After logging into the site at: www.mysmartstart.com, they must select and pay for the service plan in order to start using the system.

Notes: SmartStart response time can vary depending on cellular coverage and network congestion.
 Operating temperature range: -30°C to + 70°C.

LED Status Chart

Amber LED	
Off	No cellular communication. Check connections such as module harness.
Flashing Slowly	The module is seeking cellular system communication. If no cell coverage is available the Amber LED continues to flash slowly, move the vehicle to a location with better reception.
Flashing Quickly	The module is negotiating with a cellular system.
On Solid	Communication successfully established.
Green LED*	
Off	Communication not established with the remote start main unit or no serial device is connected. Check connection at the Bitwriter port, once connected properly the LED turns on after resetting the power to the SmartStart module.
On Solid	Communication successfully established with the remote start or Directed digital systems.

* The green LED does not light if connected to Autostart/AstroStart systems with pager ports, or in standalone mode.

Additional information can be found at: www.directechs.com

DIRECTED